

CUDA (Compute Unified Device Architecture) and OpenCL (Open Compute Language): Programming GPUs

Dr. Bharathwaj "Bharath" Muthuswamy

Visiting Assistant Professor in Computer Science
The College of New Jersey
bharath.berkeley@gmail.com

February 20th 2018

About me...

Goals and Organization

Conceptual Overview
of the Project

Understanding the
Graphics Pipeline

Part I: CUDA

Part II: OpenCL

DTCNN and OpenCL

Conclusion and Q/A

About me...

- ▶ BS (2002), MS (2005), PhD (2009) in EECS from the University of California, Berkeley
(advisors: Dr. Leon O. Chua, Dr. Pravin P. Varaiya)

CUDA (Compute Unified Device Architecture) and OpenCL (Open Compute Language): Programming GPUs

Dr. Bharathwaj
"Bharath"
Muthuswamy

About me...

Goals and Organization

Conceptual Overview of the Project

Understanding the Graphics Pipeline

Part I: CUDA

Part II: OpenCL

DTCNN and OpenCL

Conclusion and Q/A

About me...

- ▶ BS (2002), MS (2005), PhD (2009) in EECS from the University of California, Berkeley (advisors: Dr. Leon O. Chua, Dr. Pravin P. Varaiya)
 - ▶ For my MS, I worked on biomimetic bipedal robotics using Central Pattern Generators (I did not work on this after 2006)
 - ▶ For my PhD, my primary contribution was designing, implementing and rigorously proving the existence of chaos in the Muthuswamy-Chua system (circuit): an inductor-capacitor-memristor circuit in series (parallel)

CUDA (Compute Unified Device Architecture) and OpenCL (Open Compute Language): Programming GPUs

Dr. Bharathwaj
"Bharath"
Muthuswamy

About me...

Goals and Organization

Conceptual Overview of the Project

Understanding the Graphics Pipeline

Part I: CUDA

Part II: OpenCL

DTCNN and OpenCL

Conclusion and Q/A

About me...

- ▶ BS (2002), MS (2005), PhD (2009) in EECS from the University of California, Berkeley (advisors: Dr. Leon O. Chua, Dr. Pravin P. Varaiya)
 - ▶ For my MS, I worked on biomimetic bipedal robotics using Central Pattern Generators (I did not work on this after 2006)
 - ▶ For my PhD, my primary contribution was designing, implementing and rigorously proving the existence of chaos in the Muthuswamy-Chua system (circuit): an inductor-capacitor-memristor circuit in series (parallel)
- ▶ Areas of interest:
 - ▶ Computer vision and Quantum Computing
 - ▶ Nonlinear Dynamics (Circuits). Specifically: chaotic circuits and memristors
 - ▶ Embedded (FPGA) Systems and Education

CUDA (Compute Unified Device Architecture) and OpenCL (Open Compute Language): Programming GPUs

Dr. Bharathwaj
"Bharath"
Muthuswamy

About me...

Goals and Organization

Conceptual Overview of the Project

Understanding the Graphics Pipeline

Part I: CUDA

Part II: OpenCL

DTCNN and OpenCL

Conclusion and Q/A

Project goal, Presentation goal and Organization

- ▶ Goal of my research: **Implement a model for the mammalian visual pathway on a heterogeneous platform using Discrete Time Cellular Nonlinear Networks (DTCNN).**

CUDA (Compute Unified Device Architecture) and OpenCL (Open Compute Language): Programming GPUs

Dr. Bharathwaj
"Bharath"
Muthuswamy

About me...

Goals and Organization

Conceptual Overview of the Project

Understanding the Graphics Pipeline

Part I: CUDA

Part II: OpenCL

DTCNN and OpenCL

Conclusion and Q/A

Project goal, Presentation goal and Organization

- ▶ Goal of my research: **Implement a model for the mammalian visual pathway on a heterogeneous platform using Discrete Time Cellular Nonlinear Networks (DTCNN).**
 - ▶ Application: Robust recognition of hand-drawn electronic circuit diagrams
- ▶ Goal of this talk: Discuss GPU programming strategies (CUDA and OpenCL)

CUDA (Compute Unified Device Architecture) and OpenCL (Open Compute Language): Programming GPUs

Dr. Bharathwaj
"Bharath"
Muthuswamy

About me...

Goals and Organization

Conceptual Overview of the Project

Understanding the Graphics Pipeline

Part I: CUDA

Part II: OpenCL

DTCNN and OpenCL

Conclusion and Q/A

Project goal, Presentation goal and Organization

- ▶ Goal of my research: **Implement a model for the mammalian visual pathway on a heterogeneous platform using Discrete Time Cellular Nonlinear Networks (DTCNN).**
 - ▶ Application: Robust recognition of hand-drawn electronic circuit diagrams
- ▶ Goal of this talk: Discuss GPU programming strategies (CUDA and OpenCL)
- ▶ Organization:

CUDA (Compute Unified Device Architecture) and OpenCL (Open Compute Language): Programming GPUs

Dr. Bharathwaj
"Bharath"
Muthuswamy

About me...

Goals and Organization

Conceptual Overview of the Project

Understanding the Graphics Pipeline

Part I: CUDA

Part II: OpenCL

DTCNN and OpenCL

Conclusion and Q/A

Project goal, Presentation goal and Organization

- ▶ Goal of my research: **Implement a model for the mammalian visual pathway on a heterogeneous platform using Discrete Time Cellular Nonlinear Networks (DTCNN).**
 - ▶ Application: Robust recognition of hand-drawn electronic circuit diagrams
- ▶ Goal of this talk: Discuss GPU programming strategies (CUDA and OpenCL)
- ▶ Organization:
 - ▶ Conceptual Overview of the Project

CUDA (Compute Unified Device Architecture) and OpenCL (Open Compute Language): Programming GPUs

Dr. Bharathwaj
"Bharath"
Muthuswamy

About me...

Goals and Organization

Conceptual Overview of the Project

Understanding the Graphics Pipeline

Part I: CUDA

Part II: OpenCL

DTCNN and OpenCL

Conclusion and Q/A

Project goal, Presentation goal and Organization

- ▶ Goal of my research: **Implement a model for the mammalian visual pathway on a heterogeneous platform using Discrete Time Cellular Nonlinear Networks (DTCNN).**
 - ▶ Application: Robust recognition of hand-drawn electronic circuit diagrams
- ▶ Goal of this talk: Discuss GPU programming strategies (CUDA and OpenCL)
- ▶ Organization:
 - ▶ Conceptual Overview of the Project
 - ▶ Understanding the graphics pipeline

CUDA (Compute Unified Device Architecture) and OpenCL (Open Compute Language): Programming GPUs

Dr. Bharathwaj
"Bharath"
Muthuswamy

About me...

Goals and Organization

Conceptual Overview of the Project

Understanding the Graphics Pipeline

Part I: CUDA

Part II: OpenCL

DTCNN and OpenCL

Conclusion and Q/A

Project goal, Presentation goal and Organization

- ▶ Goal of my research: **Implement a model for the mammalian visual pathway on a heterogeneous platform using Discrete Time Cellular Nonlinear Networks (DTCNN).**
 - ▶ Application: Robust recognition of hand-drawn electronic circuit diagrams
- ▶ Goal of this talk: Discuss GPU programming strategies (CUDA and OpenCL)
- ▶ Organization:
 - ▶ Conceptual Overview of the Project
 - ▶ Understanding the graphics pipeline
 - ▶ Part I: CUDA - Hello, world; SAXPY

CUDA (Compute Unified Device Architecture) and OpenCL (Open Compute Language): Programming GPUs

Dr. Bharathwaj
"Bharath"
Muthuswamy

About me...

Goals and Organization

Conceptual Overview of the Project

Understanding the Graphics Pipeline

Part I: CUDA

Part II: OpenCL

DTCNN and OpenCL

Conclusion and Q/A

Project goal, Presentation goal and Organization

- ▶ Goal of my research: **Implement a model for the mammalian visual pathway on a heterogeneous platform using Discrete Time Cellular Nonlinear Networks (DTCNN).**
 - ▶ Application: Robust recognition of hand-drawn electronic circuit diagrams
- ▶ Goal of this talk: Discuss GPU programming strategies (CUDA and OpenCL)
- ▶ Organization:
 - ▶ Conceptual Overview of the Project
 - ▶ Understanding the graphics pipeline
 - ▶ Part I: CUDA - Hello, world; SAXPY
 - ▶ Part II: OpenCL - Hello, world

CUDA (Compute Unified Device Architecture) and OpenCL (Open Compute Language): Programming GPUs

Dr. Bharathwaj
"Bharath"
Muthuswamy

About me...

Goals and Organization

Conceptual Overview of the Project

Understanding the Graphics Pipeline

Part I: CUDA

Part II: OpenCL

DTCNN and OpenCL

Conclusion and Q/A

Project goal, Presentation goal and Organization

- ▶ Goal of my research: **Implement a model for the mammalian visual pathway on a heterogeneous platform using Discrete Time Cellular Nonlinear Networks (DTCNN).**
 - ▶ Application: Robust recognition of hand-drawn electronic circuit diagrams
- ▶ Goal of this talk: Discuss GPU programming strategies (CUDA and OpenCL)
- ▶ Organization:
 - ▶ Conceptual Overview of the Project
 - ▶ Understanding the graphics pipeline
 - ▶ Part I: CUDA - Hello, world; SAXPY
 - ▶ Part II: OpenCL - Hello, world
 - ▶ Current work: OpenCL specification of DTCNN

CUDA (Compute Unified Device Architecture) and OpenCL (Open Compute Language): Programming GPUs

Dr. Bharathwaj
"Bharath"
Muthuswamy

About me...

Goals and Organization

Conceptual Overview of the Project

Understanding the Graphics Pipeline

Part I: CUDA

Part II: OpenCL

DTCNN and OpenCL

Conclusion and Q/A

Project goal, Presentation goal and Organization

- ▶ Goal of my research: **Implement a model for the mammalian visual pathway on a heterogeneous platform using Discrete Time Cellular Nonlinear Networks (DTCNN).**
 - ▶ Application: Robust recognition of hand-drawn electronic circuit diagrams
- ▶ Goal of this talk: Discuss GPU programming strategies (CUDA and OpenCL)
- ▶ Organization:
 - ▶ Conceptual Overview of the Project
 - ▶ Understanding the graphics pipeline
 - ▶ Part I: CUDA - Hello, world; SAXPY
 - ▶ Part II: OpenCL - Hello, world
 - ▶ Current work: OpenCL specification of DTCNN
 - ▶ Conclusion and Q/A

CUDA (Compute Unified Device Architecture) and OpenCL (Open Compute Language): Programming GPUs

Dr. Bharathwaj
"Bharath"
Muthuswamy

About me...

Goals and Organization

Conceptual Overview of the Project

Understanding the Graphics Pipeline

Part I: CUDA

Part II: OpenCL

DTCNN and OpenCL

Conclusion and Q/A

Mammalian Retina

CUDA (Compute Unified Device Architecture) and OpenCL (Open Compute Language): Programming GPUs

Dr. Bharathwaj
"Bharath"
Muthuswamy

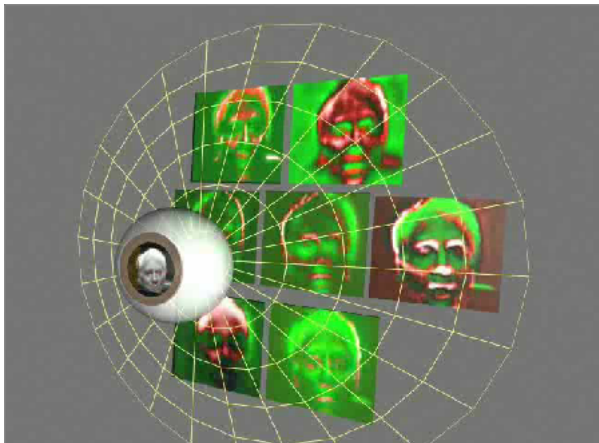

About me...

Goals and Organization

Conceptual Overview of the Project

Understanding the Graphics Pipeline

Part I: CUDA

Part II: OpenCL

DTCNN and OpenCL

Conclusion and Q/A

Block Diagram of the Project

CUDA (Compute Unified Device Architecture) and OpenCL (Open Compute Language): Programming GPUs

Dr. Bharathwaj
"Bharath"
Muthuswamy

About me...

Goals and Organization

Conceptual Overview of the Project

Understanding the Graphics Pipeline

Part I: CUDA

Part II: OpenCL

DTCNN and OpenCL

Conclusion and Q/A

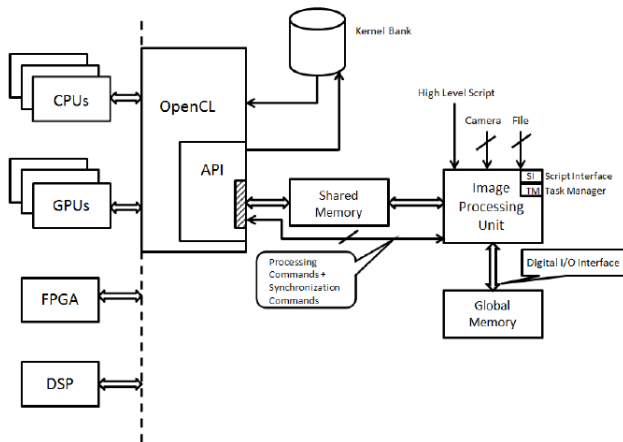

Simple Raster Graphics Pipeline

CUDA (Compute Unified Device Architecture) and OpenCL (Open Compute Language): Programming GPUs

Dr. Bharathwaj
"Bharath"
Muthuswamy

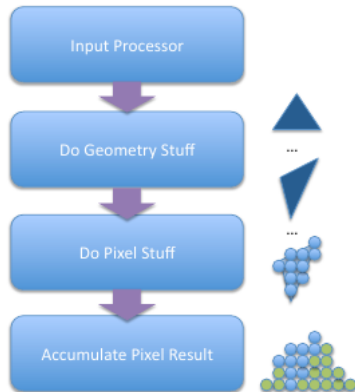

About me...

Goals and Organization

Conceptual Overview of the Project

Understanding the Graphics Pipeline

Part I: CUDA

Part II: OpenCL

DTCNN and OpenCL

Conclusion and Q/A

Enhanced Graphics Pipeline

CUDA (Compute Unified Device Architecture) and OpenCL (Open Compute Language): Programming GPUs

Dr. Bharathwaj
"Bharath"
Muthuswamy

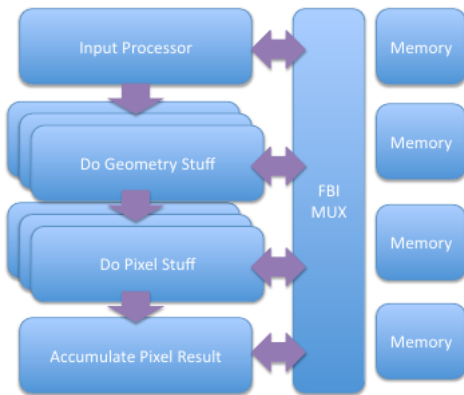

About me...

Goals and Organization

Conceptual Overview of the Project

Understanding the Graphics Pipeline

Part I: CUDA

Part II: OpenCL

DTCNN and OpenCL

Conclusion and Q/A

General Purpose Pipeline

CUDA (Compute Unified Device Architecture) and OpenCL (Open Compute Language): Programming GPUs

Dr. Bharathwaj
"Bharath"
Muthuswamy

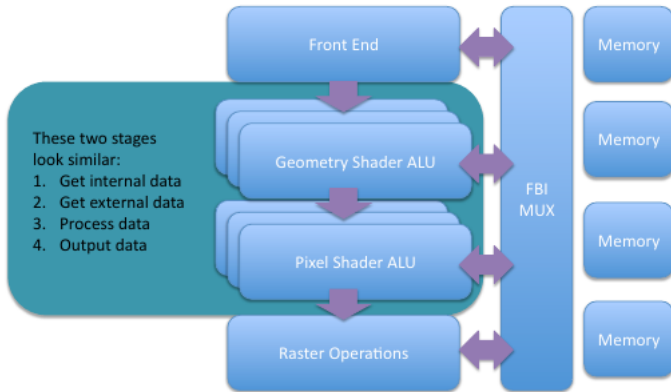

About me...

Goals and Organization

Conceptual Overview of the Project

Understanding the Graphics Pipeline

Part I: CUDA

Part II: OpenCL

DTCNN and OpenCL

Conclusion and Q/A

Shader Pipeline

CUDA (Compute Unified Device Architecture) and OpenCL (Open Compute Language): Programming GPUs

Dr. Bharathwaj
"Bharath"
Muthuswamy

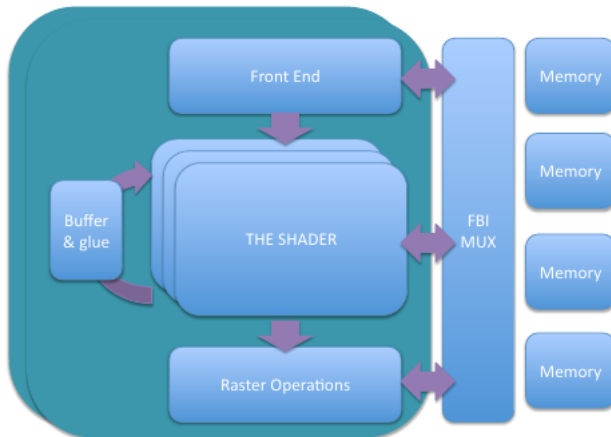

About me...

Goals and Organization

Conceptual Overview
of the Project

Understanding the
Graphics Pipeline

Part I: CUDA

Part II: OpenCL

DTCNN and OpenCL

Conclusion and Q/A

SIMD Pipeline



CUDA (Compute Unified Device Architecture) and OpenCL (Open Compute Language): Programming GPUs

Dr. Bharathwaj
"Bharath"
Muthuswamy

About me...

Goals and Organization

Conceptual Overview of the Project

Understanding the Graphics Pipeline

Part I: CUDA

Part II: OpenCL

DTCNN and OpenCL

Conclusion and Q/A

SIMD Pipeline



About me...

Goals and Organization

Conceptual Overview of the Project

Understanding the Graphics Pipeline

Part I: CUDA

Part II: OpenCL

DTCNN and OpenCL

Conclusion and Q/A

SIMT Pipeline

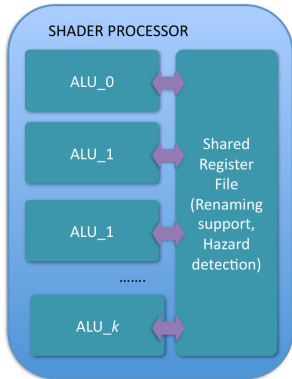

CUDA (Compute Unified Device Architecture) and OpenCL (Open Compute Language): Programming GPUs

Dr. Bharathwaj
"Bharath"
Muthuswamy

About me...

Goals and Organization

Conceptual Overview of the Project

Understanding the Graphics Pipeline

Part I: CUDA

Part II: OpenCL

DTCNN and OpenCL

Conclusion and Q/A

SIMT Pipeline

CUDA (Compute Unified Device Architecture) and OpenCL (Open Compute Language): Programming GPUs

Dr. Bharathwaj
"Bharath"
Muthuswamy

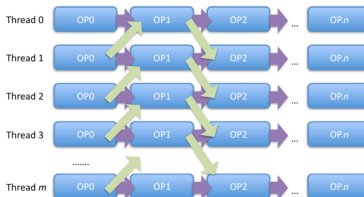
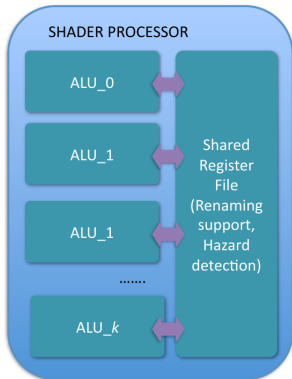

About me...

Goals and Organization

Conceptual Overview of the Project

Understanding the Graphics Pipeline

Part I: CUDA

Part II: OpenCL

DTCNN and OpenCL

Conclusion and Q/A

CUDA: High-level overview

CUDA (Compute Unified Device Architecture) and OpenCL (Open Compute Language): Programming GPUs

Dr. Bharathwaj
"Bharath"
Muthuswamy

About me...

Goals and Organization

Conceptual Overview of the Project

Understanding the Graphics Pipeline

Part I: CUDA

Part II: OpenCL

DTCNN and OpenCL

Conclusion and Q/A

- ▶ Traditional serial version of the program...

CUDA: High-level overview

CUDA (Compute Unified Device Architecture) and OpenCL (Open Compute Language): Programming GPUs

Dr. Bharathwaj
"Bharath"
Muthuswamy

- ▶ Traditional serial version of the program...
- ▶ ...that sets up subroutines or **kernels** that are to be executed in parallel

About me...

Goals and Organization

Conceptual Overview of the Project

Understanding the Graphics Pipeline

Part I: CUDA

Part II: OpenCL

DTCNN and OpenCL

Conclusion and Q/A

CUDA Examples

CUDA (Compute Unified Device Architecture) and OpenCL (Open Compute Language): Programming GPUs

Dr. Bharathwaj
"Bharath"
Muthuswamy

About me...

Goals and Organization

Conceptual Overview of the Project

Understanding the Graphics Pipeline

Part I: CUDA

Part II: OpenCL

DTCNN and OpenCL

Conclusion and Q/A

▶ <http://www.harpgroup.org/muthuswamy/computerVision/CUDA/helloWorld>

CUDA Examples

CUDA (Compute Unified Device Architecture) and OpenCL (Open Compute Language): Programming GPUs

Dr. Bharathwaj
"Bharath"
Muthuswamy

About me...

Goals and Organization

Conceptual Overview of the Project

Understanding the Graphics Pipeline

Part I: CUDA

Part II: OpenCL

DTCNN and OpenCL

Conclusion and Q/A

- ▶ <http://www.harpgroup.org/muthuswamy/computerVision/CUDA/helloWorld>
- ▶ <http://www.harpgroup.org/muthuswamy/computerVision/CUDA/saxpy>

OpenCL: High-level overview

CUDA (Compute Unified Device Architecture) and OpenCL (Open Compute Language): Programming GPUs

Dr. Bharathwaj
"Bharath"
Muthuswamy

- ▶ Think of OpenCL as a “personal robot army”:

About me...

Goals and Organization

Conceptual Overview of the Project

Understanding the Graphics Pipeline

Part I: CUDA

Part II: OpenCL

DTCNN and OpenCL

Conclusion and Q/A

OpenCL: High-level overview

CUDA (Compute Unified Device Architecture) and OpenCL (Open Compute Language): Programming GPUs

Dr. Bharathwaj
"Bharath"
Muthuswamy

- ▶ Think of OpenCL as a “personal robot army”:
 - ▶ Each robot or **OpenCL work unit** works on specific data **independent** of other robots

About me...

Goals and Organization

Conceptual Overview of the Project

Understanding the Graphics Pipeline

Part I: CUDA

Part II: OpenCL

DTCNN and OpenCL

Conclusion and Q/A

OpenCL: High-level overview

CUDA (Compute Unified Device Architecture) and OpenCL (Open Compute Language): Programming GPUs

Dr. Bharathwaj
"Bharath"
Muthuswamy

- ▶ Think of OpenCL as a “personal robot army”:
 - ▶ Each robot or **OpenCL work unit** works on specific data **independent** of other robots
 - ▶ Each robot has a unique id, robots can be grouped

About me...

Goals and Organization

Conceptual Overview of the Project

Understanding the Graphics Pipeline

Part I: CUDA

Part II: OpenCL

DTCNN and OpenCL

Conclusion and Q/A

OpenCL: High-level overview

CUDA (Compute Unified Device Architecture) and OpenCL (Open Compute Language): Programming GPUs

Dr. Bharathwaj
"Bharath"
Muthuswamy

- ▶ Think of OpenCL as a “personal robot army”:
 - ▶ Each robot or **OpenCL work unit** works on specific data **independent** of other robots
 - ▶ Each robot has a unique id, robots can be grouped
- ▶ Limitation: data-parallelism (see example of DTCNN later)

About me...

Goals and Organization

Conceptual Overview of the Project

Understanding the Graphics Pipeline

Part I: CUDA

Part II: OpenCL

DTCNN and OpenCL

Conclusion and Q/A

OpenCL: Steps

- ▶ Get list of available platforms

CUDA (Compute Unified Device Architecture) and OpenCL (Open Compute Language): Programming GPUs

Dr. Bharathwaj
"Bharath"
Muthuswamy

About me...

Goals and Organization

Conceptual Overview of the Project

Understanding the Graphics Pipeline

Part I: CUDA

Part II: OpenCL

DTCNN and OpenCL

Conclusion and Q/A

OpenCL: Steps

- ▶ Get list of available platforms
- ▶ Use platforms to select appropriate device(s)

CUDA (Compute Unified Device Architecture) and OpenCL (Open Compute Language): Programming GPUs

Dr. Bharathwaj
"Bharath"
Muthuswamy

About me...

Goals and Organization

Conceptual Overview of the Project

Understanding the Graphics Pipeline

Part I: CUDA

Part II: OpenCL

DTCNN and OpenCL

Conclusion and Q/A

OpenCL: Steps

- ▶ Get list of available platforms
- ▶ Use platforms to select appropriate device(s)
- ▶ Create an OpenCL context

CUDA (Compute Unified Device Architecture) and OpenCL (Open Compute Language): Programming GPUs

Dr. Bharathwaj
"Bharath"
Muthuswamy

About me...

Goals and Organization

Conceptual Overview of the Project

Understanding the Graphics Pipeline

Part I: CUDA

Part II: OpenCL

DTCNN and OpenCL

Conclusion and Q/A

OpenCL: Steps

- ▶ Get list of available platforms
- ▶ Use platforms to select appropriate device(s)
- ▶ Create an OpenCL context
- ▶ Create command queue

CUDA (Compute Unified Device Architecture) and OpenCL (Open Compute Language): Programming GPUs

Dr. Bharathwaj
"Bharath"
Muthuswamy

About me...

Goals and Organization

Conceptual Overview of the Project

Understanding the Graphics Pipeline

Part I: CUDA

Part II: OpenCL

DTCNN and OpenCL

Conclusion and Q/A

OpenCL: Steps

- ▶ Get list of available platforms
- ▶ Use platforms to select appropriate device(s)
- ▶ Create an OpenCL context
- ▶ Create command queue
- ▶ Create memory objects

CUDA (Compute Unified Device Architecture) and OpenCL (Open Compute Language): Programming GPUs

Dr. Bharathwaj
"Bharath"
Muthuswamy

[About me...](#)

[Goals and Organization](#)

[Conceptual Overview of the Project](#)

[Understanding the Graphics Pipeline](#)

[Part I: CUDA](#)

[Part II: OpenCL](#)

[DTCNN and OpenCL](#)

[Conclusion and Q/A](#)

OpenCL: Steps

- ▶ Get list of available platforms
- ▶ Use platforms to select appropriate device(s)
- ▶ Create an OpenCL context
- ▶ Create command queue
- ▶ Create memory objects
- ▶ Create kernel

CUDA (Compute Unified Device Architecture) and OpenCL (Open Compute Language): Programming GPUs

Dr. Bharathwaj
"Bharath"
Muthuswamy

[About me...](#)

[Goals and Organization](#)

[Conceptual Overview of the Project](#)

[Understanding the Graphics Pipeline](#)

[Part I: CUDA](#)

[Part II: OpenCL](#)

[DTCNN and OpenCL](#)

[Conclusion and Q/A](#)

OpenCL: Steps

- ▶ Get list of available platforms
- ▶ Use platforms to select appropriate device(s)
- ▶ Create an OpenCL context
- ▶ Create command queue
- ▶ Create memory objects
- ▶ Create kernel
 - ▶ Load kernel specified via OpenCL C-extension(s)

CUDA (Compute Unified Device Architecture) and OpenCL (Open Compute Language): Programming GPUs

Dr. Bharathwaj
"Bharath"
Muthuswamy

About me...

Goals and Organization

Conceptual Overview of the Project

Understanding the Graphics Pipeline

Part I: CUDA

Part II: OpenCL

DTCNN and OpenCL

Conclusion and Q/A

OpenCL: Steps

- ▶ Get list of available platforms
- ▶ Use platforms to select appropriate device(s)
- ▶ Create an OpenCL context
- ▶ Create command queue
- ▶ Create memory objects
- ▶ Create kernel
 - ▶ Load kernel specified via OpenCL C-extension(s)
 - ▶ Compile kernel to obtain kernel object

CUDA (Compute Unified Device Architecture) and OpenCL (Open Compute Language): Programming GPUs

Dr. Bharathwaj
"Bharath"
Muthuswamy

About me...

Goals and Organization

Conceptual Overview of the Project

Understanding the Graphics Pipeline

Part I: CUDA

Part II: OpenCL

DTCNN and OpenCL

Conclusion and Q/A

OpenCL: Steps

- ▶ Get list of available platforms
- ▶ Use platforms to select appropriate device(s)
- ▶ Create an OpenCL context
- ▶ Create command queue
- ▶ Create memory objects
- ▶ Create kernel
 - ▶ Load kernel specified via OpenCL C-extension(s)
 - ▶ Compile kernel to obtain kernel object
 - ▶ Set any kernel parameters

CUDA (Compute Unified Device Architecture) and OpenCL (Open Compute Language): Programming GPUs

Dr. Bharathwaj
"Bharath"
Muthuswamy

[About me...](#)

[Goals and Organization](#)

[Conceptual Overview of the Project](#)

[Understanding the Graphics Pipeline](#)

[Part I: CUDA](#)

[Part II: OpenCL](#)

[DTCNN and OpenCL](#)

[Conclusion and Q/A](#)

OpenCL: Steps

- ▶ Get list of available platforms
- ▶ Use platforms to select appropriate device(s)
- ▶ Create an OpenCL context
- ▶ Create command queue
- ▶ Create memory objects
- ▶ Create kernel
 - ▶ Load kernel specified via OpenCL C-extension(s)
 - ▶ Compile kernel to obtain kernel object
 - ▶ Set any kernel parameters
- ▶ Execute the kernel

CUDA (Compute Unified Device Architecture) and OpenCL (Open Compute Language): Programming GPUs

Dr. Bharathwaj
"Bharath"
Muthuswamy

About me...

Goals and Organization

Conceptual Overview of the Project

Understanding the Graphics Pipeline

Part I: CUDA

Part II: OpenCL

DTCNN and OpenCL

Conclusion and Q/A

OpenCL: Steps

- ▶ Get list of available platforms
- ▶ Use platforms to select appropriate device(s)
- ▶ Create an OpenCL context
- ▶ Create command queue
- ▶ Create memory objects
- ▶ Create kernel
 - ▶ Load kernel specified via OpenCL C-extension(s)
 - ▶ Compile kernel to obtain kernel object
 - ▶ Set any kernel parameters
- ▶ Execute the kernel
- ▶ Read result from previously created memory object

CUDA (Compute Unified Device Architecture) and OpenCL (Open Compute Language): Programming GPUs

Dr. Bharathwaj
"Bharath"
Muthuswamy

About me...

Goals and Organization

Conceptual Overview of the Project

Understanding the Graphics Pipeline

Part I: CUDA

Part II: OpenCL

DTCNN and OpenCL

Conclusion and Q/A

OpenCL: Steps

- ▶ Get list of available platforms
- ▶ Use platforms to select appropriate device(s)
- ▶ Create an OpenCL context
- ▶ Create command queue
- ▶ Create memory objects
- ▶ Create kernel
 - ▶ Load kernel specified via OpenCL C-extension(s)
 - ▶ Compile kernel to obtain kernel object
 - ▶ Set any kernel parameters
- ▶ Execute the kernel
- ▶ Read result from previously created memory object
- ▶ Free memory

CUDA (Compute Unified Device Architecture) and OpenCL (Open Compute Language): Programming GPUs

Dr. Bharathwaj
"Bharath"
Muthuswamy

About me...

Goals and Organization

Conceptual Overview of the Project

Understanding the Graphics Pipeline

Part I: CUDA

Part II: OpenCL

DTCNN and OpenCL

Conclusion and Q/A

OpenCL: Example

CUDA (Compute Unified Device Architecture) and OpenCL (Open Compute Language): Programming GPUs

Dr. Bharathwaj
"Bharath"
Muthuswamy

About me...

Goals and Organization

Conceptual Overview of the Project

Understanding the Graphics Pipeline

Part I: CUDA

Part II: OpenCL

DTCNN and OpenCL

Conclusion and Q/A

▶ <http://www.harpgroup.org/muthuswamy/computerVision/OpenCL/helloWorld>

(DT)CNN: Concept(s)

- ▶ $M \times N$ CNN architecture:

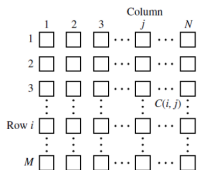

CUDA (Compute Unified Device Architecture) and OpenCL (Open Compute Language): Programming GPUs

Dr. Bharathwaj
"Bharath"
Muthuswamy

About me...

Goals and Organization

Conceptual Overview of the Project

Understanding the Graphics Pipeline

Part I: CUDA

Part II: OpenCL

DTCNN and OpenCL

Conclusion and Q/A

(DT)CNN: Concept(s)

- ▶ $M \times N$ CNN architecture:

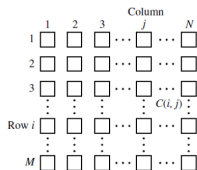

- ▶ State equation and output equation (nonlinear):

$$\dot{x}_{ij} = -x_{ij} + \sum_{C(k,l) \in S_r(i,j)} A(i, j; k, l) y_{kl} + \sum_{C(k,l) \in S_r(i,j)} B(i, j; k, l) u_{kl} + z_{ij}$$

$$y_{ij} = \frac{1}{2} (|x_{ij} + 1| - |x_{ij} - 1|)$$

(DT)CNN: Concept(s)

- ▶ $M \times N$ CNN architecture:

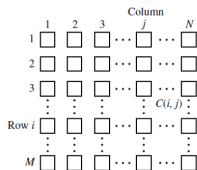

- ▶ State equation and output equation (nonlinear):

$$\dot{x}_{ij} = -x_{ij} + \sum_{C(k,l) \in S_r(i,j)} A(i, j; k, l) y_{kl} + \sum_{C(k,l) \in S_r(i,j)} B(i, j; k, l) u_{kl} + z_{ij}$$

$$y_{ij} = \frac{1}{2} (|x_{ij} + 1| - |x_{ij} - 1|)$$

- ▶ DTCNN:

$$X_{i,j}(t+1) \approx \sum_{c(k,l) \in N r(i,j)} A(i, j; k, l) f(X_{k,l}(t)) + \sum_{c(k,l) \in N r(i,j)} B(i, j; k, l) U_{k,l} + I$$

OpenCL flow

- ▶ DTCNN state equation can be written as:

$$x_{ij}(t+1) = T_A * y_{kl}(n) + T_B * u_{kl} + I$$

CUDA (Compute Unified Device Architecture) and OpenCL (Open Compute Language): Programming GPUs

Dr. Bharathwaj
"Bharath"
Muthuswamy

About me...

Goals and Organization

Conceptual Overview of the Project

Understanding the Graphics Pipeline

Part I: CUDA

Part II: OpenCL

DTCNN and OpenCL

Conclusion and Q/A

OpenCL flow

- ▶ DTCNN state equation can be written as:

$$x_{ij}(t+1) = T_A * y_{kl}(n) + T_B * u_{kl} + I$$

- ▶ Proposed OpenCL implementation:

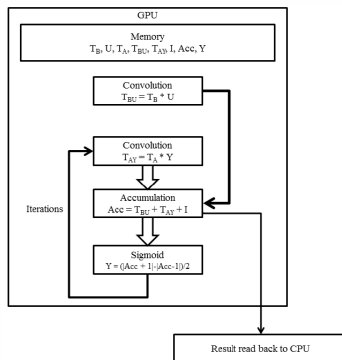

About me...

Goals and Organization

Conceptual Overview of the Project

Understanding the Graphics Pipeline

Part I: CUDA

Part II: OpenCL

DTCNN and OpenCL

Conclusion and Q/A

Conclusion and Q/A

- ▶ Current work: Implementing various retinal “filters” via DTCNN using OpenCL
- ▶ Future work: post-processing of images obtained from hand-drawn electronic circuit diagrams:
 - ▶ Deep learning (?): Learn data representations, but use images obtained from retinal “filters”. Note: it is known the visual cortex processes in **parallel** the images obtained from the retina
- ▶ *Potential* funding:
<https://www.grants.gov/web/grants/view-opportunity.html?oppld=300721>
- ▶ Reference: Detailed howto and code is online:
<http://www.harpgroup.org/muthuswamy/computerVision>

CUDA (Compute Unified Device Architecture) and OpenCL (Open Compute Language): Programming GPUs

Dr. Bharathwaj
“Bharath”
Muthuswamy

About me...

Goals and Organization

Conceptual Overview of the Project

Understanding the Graphics Pipeline

Part I: CUDA

Part II: OpenCL

DTCNN and OpenCL

Conclusion and Q/A